

Positioning the 'CLEANVENT' CVAD  
Combined microbubble air & dirt separator  
in the system is important for optimum performance.

In heating systems this should be in the flow, preferably at the highest temperature  
(next to the heat source) and low pressure if possible.

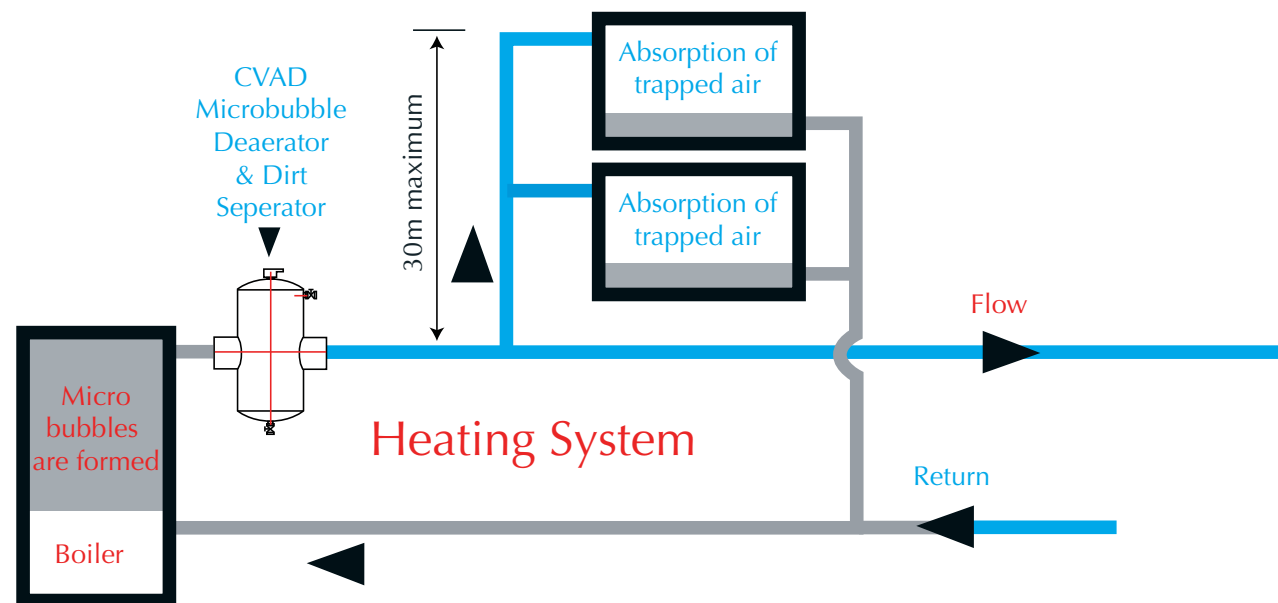

## The Cleanvent Microbubble Air & Dirt Separators (CVAD)



The Air Free & Clean Solution

An air & dirt free water system through one unit

## Dirt Removal

The Cleanvent is also used to remove dirt particles from heating and chilled water systems. Installed it will eliminate all dirt particles down to 10 microns.

## Features

- Greatly reduced commissioning times after initial fill.
- Longer system life (through air and dirt elimination)
- Low-pressure drop
- Bi-directional flow
- Max.temp. 110 c
- Max. Working pressure 10 bar
- Tested to 21 bar
- Standard carbon steel shell (stainless on request)
- Air collects in the air chamber before being automatically vented
- Floating dirt can be removed by opening the valve situated on the side of the unit.
- The same valve is used for releasing air when filling the system
- Large collector ensures that flushing is only required now and then
- Can be flushed while fully operational (no need to shut down)
- An internal stainless steel concentrator to aid removal of air and dirt.

## Cleanvent Location

This combined unit (our model ref CVAD) must be installed at the hottest part of the system (before the pumps). In a heating system this is the main flow from the boilers.

The static head must not exceed 30 metres.

The maximum flow rates through the Cleanvent is 3m/sec. If these values are exceeded the efficiency is reduced.

## Commissioning

The Cleanvent requires no special commissioning. All units are fitted with a fast bleed valve, which should be used when initially filling the system. The same valve is used for draining off floating scum and also prevents the possibility of dirt clogging the air vent. Maintenance will be required to remove trapped dirt and sludge. Opening the ball valve at the bottom of the unit does this. The valve may be opened while the system is under pressure.

Scalding is a danger at high pressures and temperatures. Ensure that the water is safely piped to drain before opening the valve.

The system pressure will flush the dirt out. Leave the valve open until the collected dirt has been flushed out, repeat this operation every few days. Once the water is clear it may be possible to drain every 6 months or so depending on the size and age of the system.

Most of the dissolved air will be removed in a few days. However this may vary from system to system. In large systems it may take several weeks.

Dirt separators can only remove dirt that is circulating.

## Flanges

All flanges are drilled to BS 4504 PN16 as standard. Plain ends and other flange rating are available on request. The Cleanvent unit is maintenance free.

## Drain valve

All models are supplied with a ball valve for draining the collected dirt and sludge.

## Combined unit Air (de-aerator)-& Dirt Separator-Model CVAD

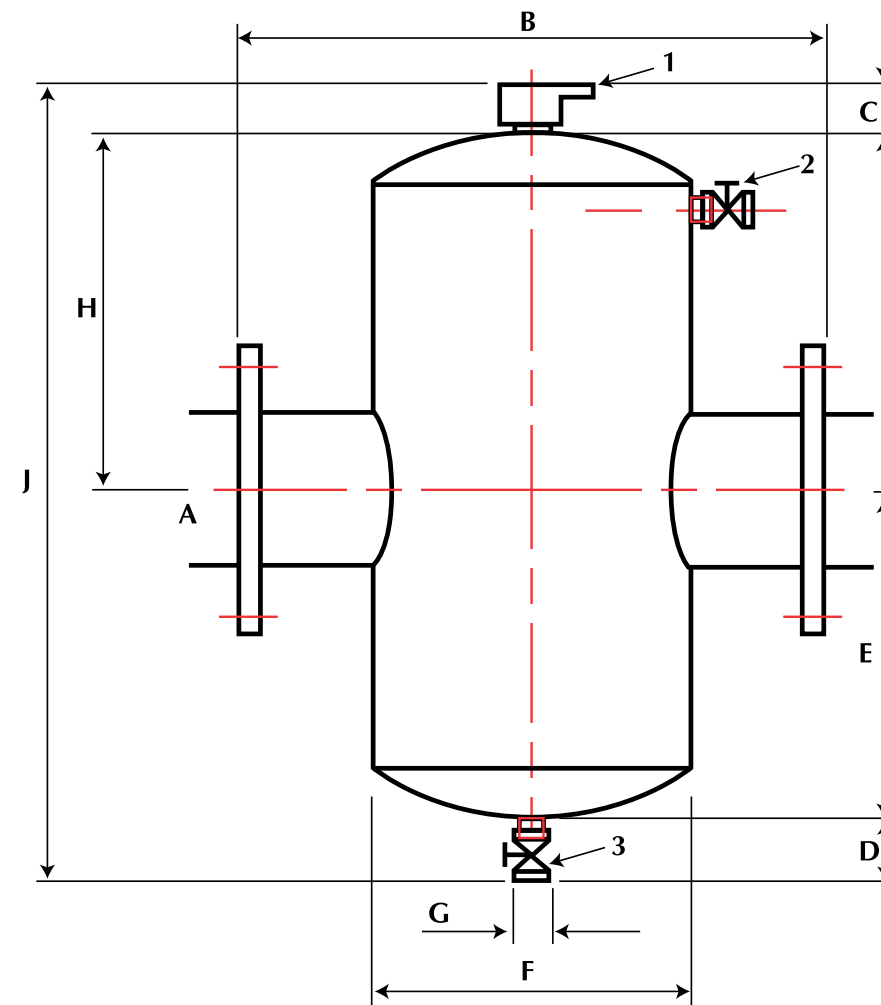

1. High Capacity Auto Air Vent
2. Fast Bleed Valve
3. Drain Valve

Product Code	Dimensions									Max WRK Press	Test Press
	A	B	C	D	E	F	G	H	J		
CVAD-50	2"	350	130	120	170	170	25	170	590	10 Bar	21 Bar
CVAD-65	2½"	350	130	120	170	170	25	170	590	10 Bar	21 Bar
CVAD-80	3"	460	130	120	210	220	25	280	740	10 Bar	21 Bar
CVAD-100	4"	460	130	120	210	220	25	280	740	10 Bar	21 Bar
CVAD-125	5"	630	130	120	330	325	25	380	960	10 Bar	21 Bar
CVAD-150	6"	630	130	120	330	325	25	380	960	10 Bar	21 Bar
CVAD-200	8"	810	130	200	390	410	50	410	1130	10 Bar	21 Bar
CVAD-250	10"	880	130	200	440	510	50	640	1410	10 Bar	21 Bar
CVAD-300	12"	1100	130	200	560	610	50	890	1780	10 Bar	21 Bar
CVAD-350	14"	1100	130	200	560	770	50	900	1790	10 Bar	21 Bar
CVAD-400	16"	1250	130	200	700	770	50	1000	2030	10 Bar	21 Bar
CVAD-450	18"	1250	130	200	700	920	50	1000	2030	10 Bar	21 Bar